

VentA Hood® ISLAND RANGE HOOD SPECIFICATIONS

PL18/PLH18/PLX18/PLXH18/PY18/PYH18 "H" in part number indicates halogen lighting. These models not available with heat lamps.

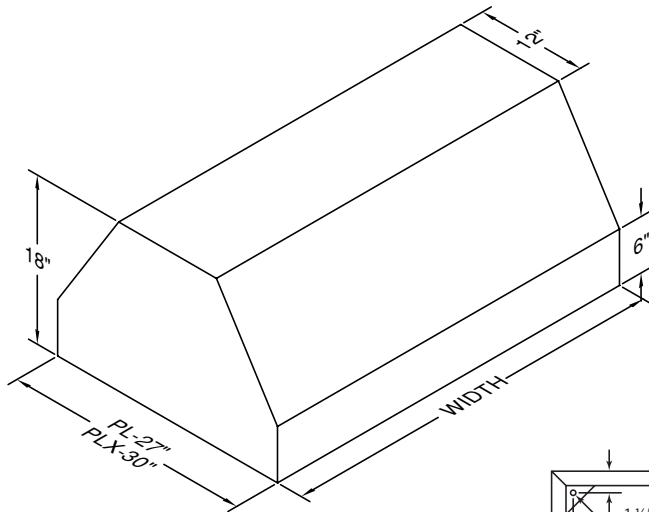

PL(X)18/PL(X)H18
"X" in model number indicates 30" depth

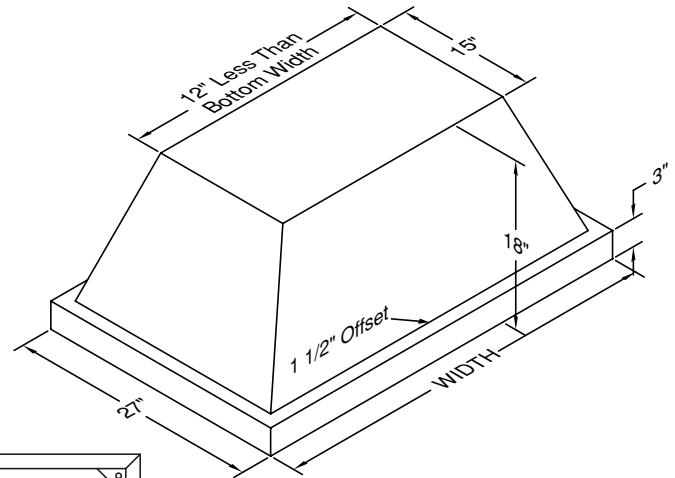

PY18/PYH18

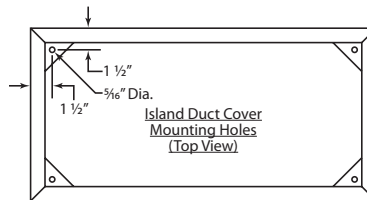

Connection Diagram (36" - 54")

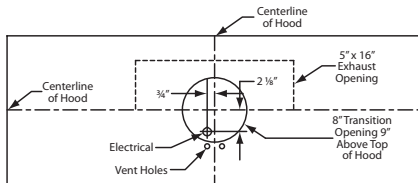

550 CFM T200 Dual Blower (Top View)

Connection Diagram (60" - 66")

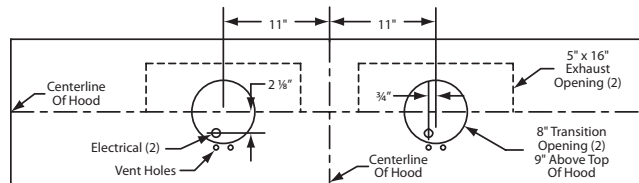

1100 CFM T2+ 200 Dual Blowers (Top View)

Recommended Mounting Height*

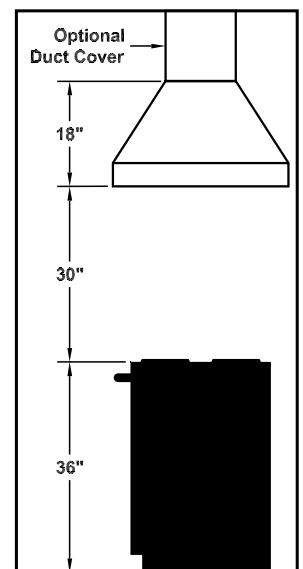

*Exceeding recommended mounting height may compromise performance.

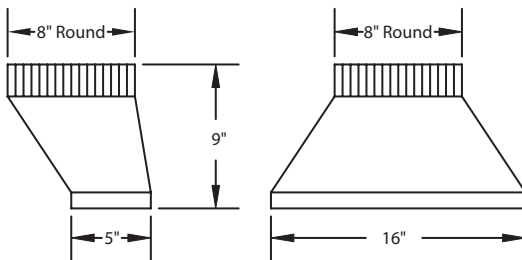

VP565 Standard Transition (Included)

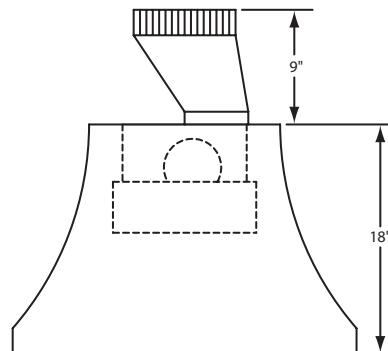

Transition Installed (Side View)

Electrical/Mechanical Specifications For Blower Units

Model	Volts	Amps*	Hz	RPM	CFM SP@0.0"	Equivalent CFM*	CFM SP@0.1"	CFM SP@0.2"	CFM SP@0.3"	Minimum Round Duct Size	Sones#
T200 Island Dual	115	2.9	60	1550	550	900	507	471	431	8" (50 in. ²)	6.0

* Add 0.5 amp for each halogen light. Hood is available with fluorescent lights (two for each dual blower) or with halogen lights (one in each corner).
 # Because the Magic Lung® blower uses centrifugal filtration rather than conventional baffle or mesh filters, the Magic Lung® blower can handle cooking equipment with higher cubic feet per minute (CFM) requirements and can deliver equivalent CFM much more efficiently than other filtration systems. When comparing the Magic Lung® with other blower units made by other manufacturers, use the "Equivalent CFM".
 # Ratings in accordance with the Standard Test Code by the Energy Systems Laboratory of the Texas Engineering Experiment Station.

