

VentA Hood® ISLAND RANGE HOOD SPECIFICATIONS

ISLH30/PYH30 Equipped with LED lighting. Not available with heat lamps.

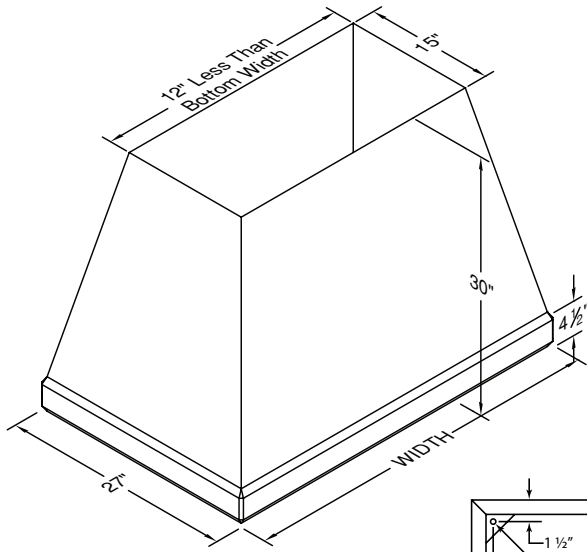

ISLH30

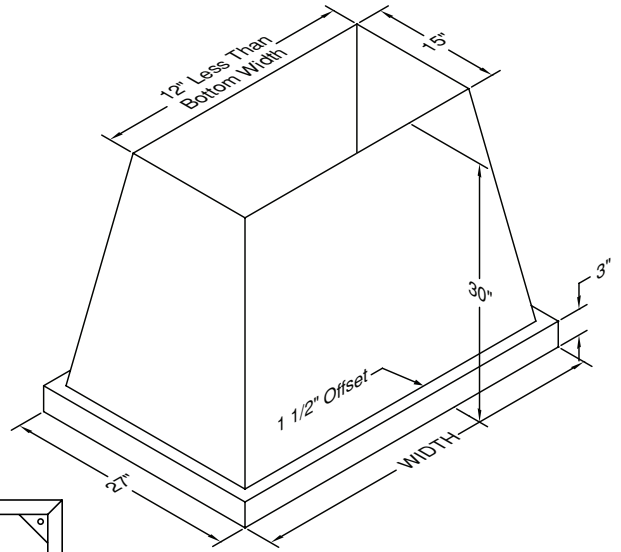

PYH30

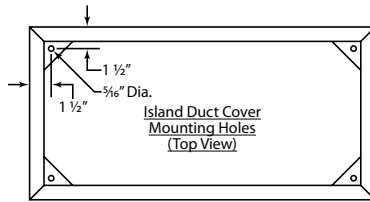

Connection Diagram (36" - 54")

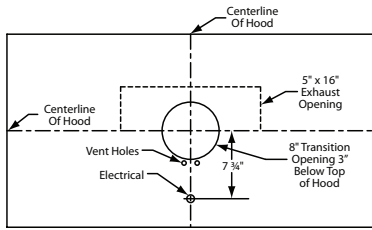

550 CFM T200 Dual Blower (Top View)

Connection Diagram (60" - 66")

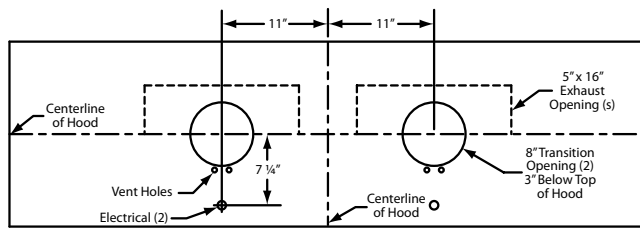

1100 CFM T2+ 200 Dual Blowers (Top View)

Recommended Mounting Height*

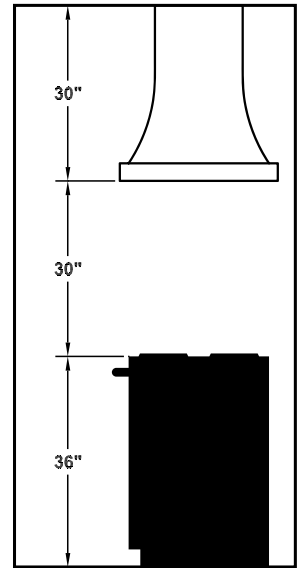

*Recommended mounting height is for optimum performance.

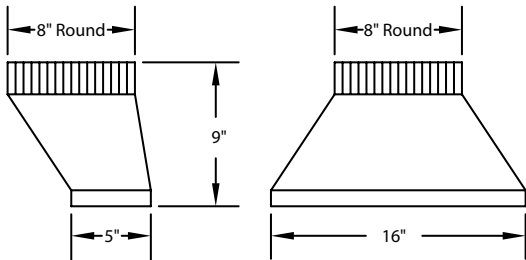

VP565 Standard Transition (Included)

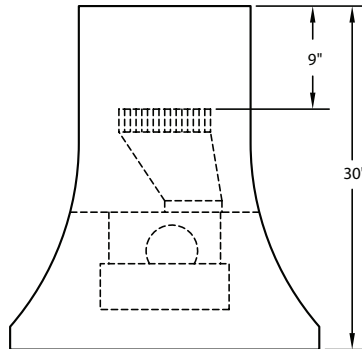

Transition Installed (Side View)

Electrical/Mechanical Specifications For Blower Units

Model	Volts	Amps	Hz	RPM	CFM SP@0.0"	Equivalent CFM*	CFM SP@0.1"	CFM SP@0.2"	CFM SP@0.3"	Minimum Round Duct Size	Sones#
T200 Island Dual	115	4.0	60	1550	550	900	507	471	431	8" (50 in. ²)	6.0
Two T200 Island Duals	115	7.5	60	1550	1100	1800	1014	942	862	Two 8" (50 in. ²)	6.0

Hood is available with LED lights (4 lights: 36" - 59"; 6 lights: 60" - 66"; +2 lights for each 14" if over 66").

* Because the Magic Lung® blower uses centrifugal filtration rather than conventional baffle or mesh filters, the Magic Lung® blower can handle cooking equipment with higher cubic feet per minute (CFM) requirements and can deliver equivalent CFM much more efficiently than other filtration systems. When comparing the Magic Lung® with other blower units made by other manufacturers, use the "Equivalent CFM".

Ratings in accordance with the Standard Test Code by the Energy Systems Laboratory of the Texas Engineering Experiment Station.